



VINDUS FAN 

REIMAGINED AIRFLOW

PRODUCT CATALOGUE

VINDUS FANS
PROVIDES AN **ENERGY SAVING SOLUTION**
THAT WILL DRAMATICALLY **REDUCE**
YOUR **ENERGY COST** BY

UP TO **30%** ON AC COOLING
DURING SUMMER

UP TO **45%** ON HEATING
DURING WINTER



01

INTRODUCTION

02

BENEFITS

05

APPLICATIONS

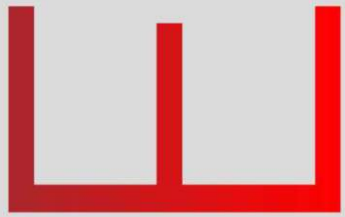

11

M650

13

M750

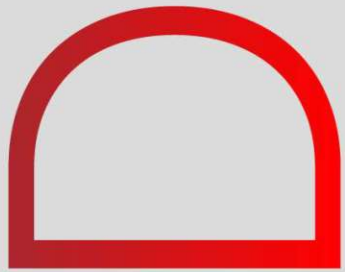

15

C400

17

M500

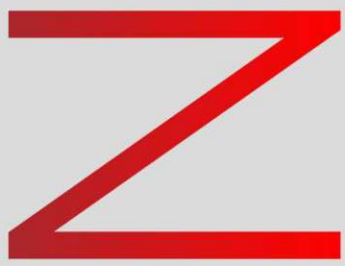

19

HMI BI 1-20

21

TECHNOLOGY



23

COMPANY

24

CONTACT

INTRODUCTION

Most people who need to solve a problem tend to only look at a fraction of their options before making a purchasing decision. This can lead them to miss out on some of the best fans on the market. One example of this is the general lack of understanding that consumers have about high-volume, low-speed (HVLS) fans and how effective they are to cool, heat, reduce moisture and odor inside a building, both indoors and outdoors.

HVLS fans are carefully designed to provide users with more functionality than traditional fans do. In this catalogue, you'll find the information that you need to know about this type of fan. You'll also learn why purchasing an HVLS could be a much smarter investment, which pays back itself, the next time that you need a climatization solution.

What is an HVLS Fan?

It's useful to start this analysis with an overview of what HVLS fans are supposed to be. Technically speaking, a high-volume, low-speed fan is any ceiling fan that is greater than 7 feet in diameter and goes all the way up to 24 feet diameter. This increased size is the hallmark of HVLS fans because it impacts how they operate. HVLS fans use their size to move air throughout large spaces and keep your entire structure comfortable. Their long blades create a powerful flow of air that spreads throughout the space like an ocean breeze. Traditional fans rely on speed to do this, which isn't usually as effective of an option nor is it as comfortable.

High Volume	Low Speed
<ul style="list-style-type: none">• Longer blades create a wider column of air• Wider columns of air travel further• Deep horizontal floor jets impact all adjacent areas	<ul style="list-style-type: none">• Gentle air movement rather than disruptive wind• Nearly silent operation• Low velocity reduces the power required to drive the fan

Therefore, High Volume Low Speed fans are currently the most inexpensive and energy-efficient way to cool down people and livestock and to recover heat from the ceilings in large buildings.

BENEFITS

THERMAL COMFORT



Air movement has a significant influence on human thermal comfort. Wind chill in cold conditions is considered detrimental, while it is considered beneficial in neutral to warm environments.

This is because normally under conditions with air temperatures above 73° F, the body needs to lose heat in order to maintain a constant internal temperature. Heat stress reduces workers productivity and increases work related errors. Therefore, HVLS fans can improve employee productivity in the summer.

“Unlike air conditioners, which cool rooms, HVLS cool people.”

Vindus fans increase air speed at the occupant level, which facilitates more efficient heat rejection, cooling the occupant, rather than the space. Elevated air speed increases the rate of convective and evaporative heat loss from the body, thus making the occupant feel cooler without changing the dry bulb temperature of the air. Just like a breeze on a hot summer day, the HVLS fans' cooling effect reduces the perceived temperature by 10-15° F, thereby generating **AC energy savings of up to 30%**. The same applies in outdoor spaces where HVLS ceiling fans provide the same high-powered air circulation that they would in an indoor setting. This is also true for animals, livestock like dairy cows who produce more when they're comfortable.

DESTRATIFICATION



In Winter, hot air is less dense than cold air, which causes hot air to naturally rise to the ceiling level through a process called convection. This is a given circumstance in large commercial and industrial spaces with high ceilings. Where there is still air, layers of constant temperature is formed – the coldest at the bottom and the warmest at the top. This is called stratification. HVLS fans are the most efficient and effective way of mixing air in a stratified space by pushing the hot air trapped in the ceiling down to the occupant level.

This allows for complete mixing of the air in the space while decreasing both heat loss through the buildings' walls and roof, reducing building energy consumption. In the winter, HVLS fans are used for heat recovery and for reducing heating costs with **energy savings of up to 45%**.

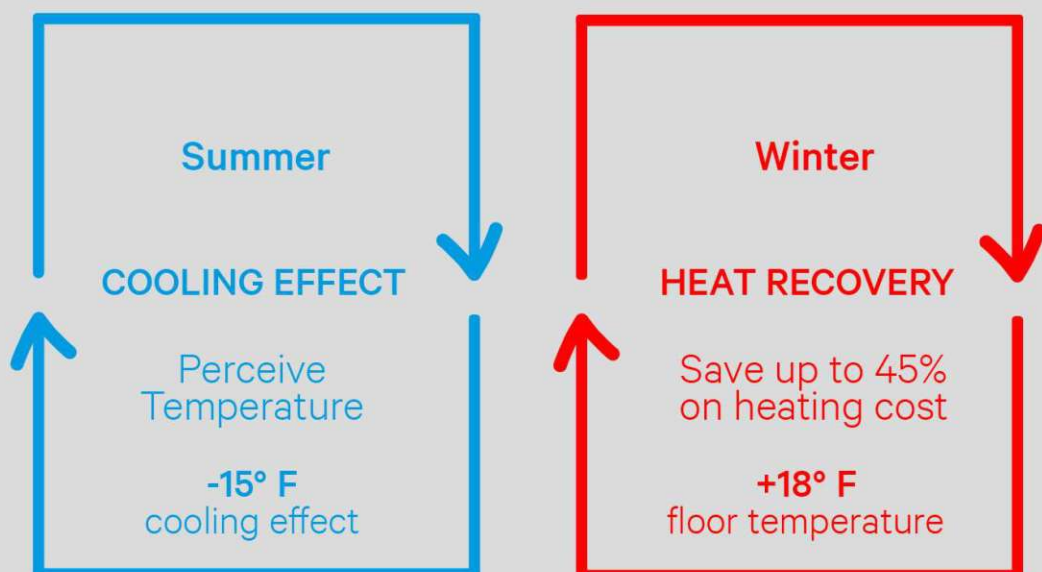



HVLS FANS OPERATE MORE EFFICIENTLY



Even setting aside all of the benefits provided by HVLS fans' improved air circulation, these fans are worth investing in because they cost less to run. A single HVLS fan can be powered using a low scale 1/2 to 2-hp motor. They consume power at a fraction of the power consumed by the dozens of small fans you would need to replace a single HVLS fan. This is, in large part, due to the size and design of modern HVLS fans. These large industrial ceiling fans are carefully designed to use less energy, operating as effectively as possible while costing you a fraction of what it costs to install and run a commercial air condition system. On top of the remarkable energy savings, these fans are actually quieter than many other cooling solutions, such as traditional ceiling fans and HVAC systems, which makes them ideal for both industrial and commercial spaces.

HVLS FANS ALSO REDUCE EXCESSIVE MOISTURE



Moisture is another major concern for commercial, sporting and farming fan customers. Excessive air moisture acts like humidity in that it can make occupants of a building feel hotter and more uncomfortable than they would if there was less moisture in the air. Even worse, it can lead to mold growth and wood rot, which could damage the items you're holding in your warehouse; or to odor and moisture issues in fitness facilities, which would discourage your patrons. Large ceiling fans are perfect for warehouse climate control. They are highly efficient in keeping your workers breathing fresh air, allowing the occupants to remain comfortable and productive without eating into your profits. Vindus Fans are also capable of reducing excessive moisture in the air in livestock environments and keep the barn floors dryer. This can provide your cattle with even more comfort, leading to even more impressive production outcomes. HVLS fans fight back against excess moisture by continuously redistributing air. Traditional fans simply can't achieve the same effect since they rely on speed to move air and not their size. Given this, if humidity or moisture is a problem in your building, then HVLS fans are the only logical way to deal with it. Other options for treating these issues would be much more expensive and not worth the investment.

HVLS FANS IMPROVE AIR QUALITY



The air circulation power that HVLS fans provide can even improve the air quality in your building. Studies have shown that stagnant air pockets have one of the highest risks for airborne bacterial growth. This is an issue that can be exacerbated when your building has excess humidity or moisture in it. HVLS fans stop this problem before it ever happens. With their superior air circulation, HVLS fans prevent stagnant air pockets from forming, thereby reducing your need to worry about issues like airborne bacterial growth and providing a healthier environment for your production activity.

- Vindus Fans reduce or eliminate slab sweating syndrome (SSS)
- Vindus Fans reduce or eliminate sick building syndrome (SBS), improving air movement within the building
- Vindus Fans can keep bugs, birds, dust, & hygienic floors under control in livestock environments.

IMPROVED AIR CIRCULATION REDUCES HUMIDITY



HVLS fans move large quantities of air towards the floor in a column. Once the air reaches the floor it will continue to flow horizontally in all directions until reaching a wall (or airflow from another fan). At this point, that air turns upward to the ceiling and back to the fan. This is important because HVLS fans involve the whole volume of air inside the space by mixing hot, cool, moist and dry air together for optimum air quality. The process by which HVLS fans operate creates convection-like air currents. This increases the air circulation in a room, removing hot and humid air and replacing it with drier air.

This is very beneficial to the plants that you're growing in agricultural facilities where air exchange is necessary for growth and too much humidity can encourage the growth of mildews, pathogens, and pests.

MANUFACTURING FACILITIES





COMMERCIAL BUILDINGS

EDUCATION



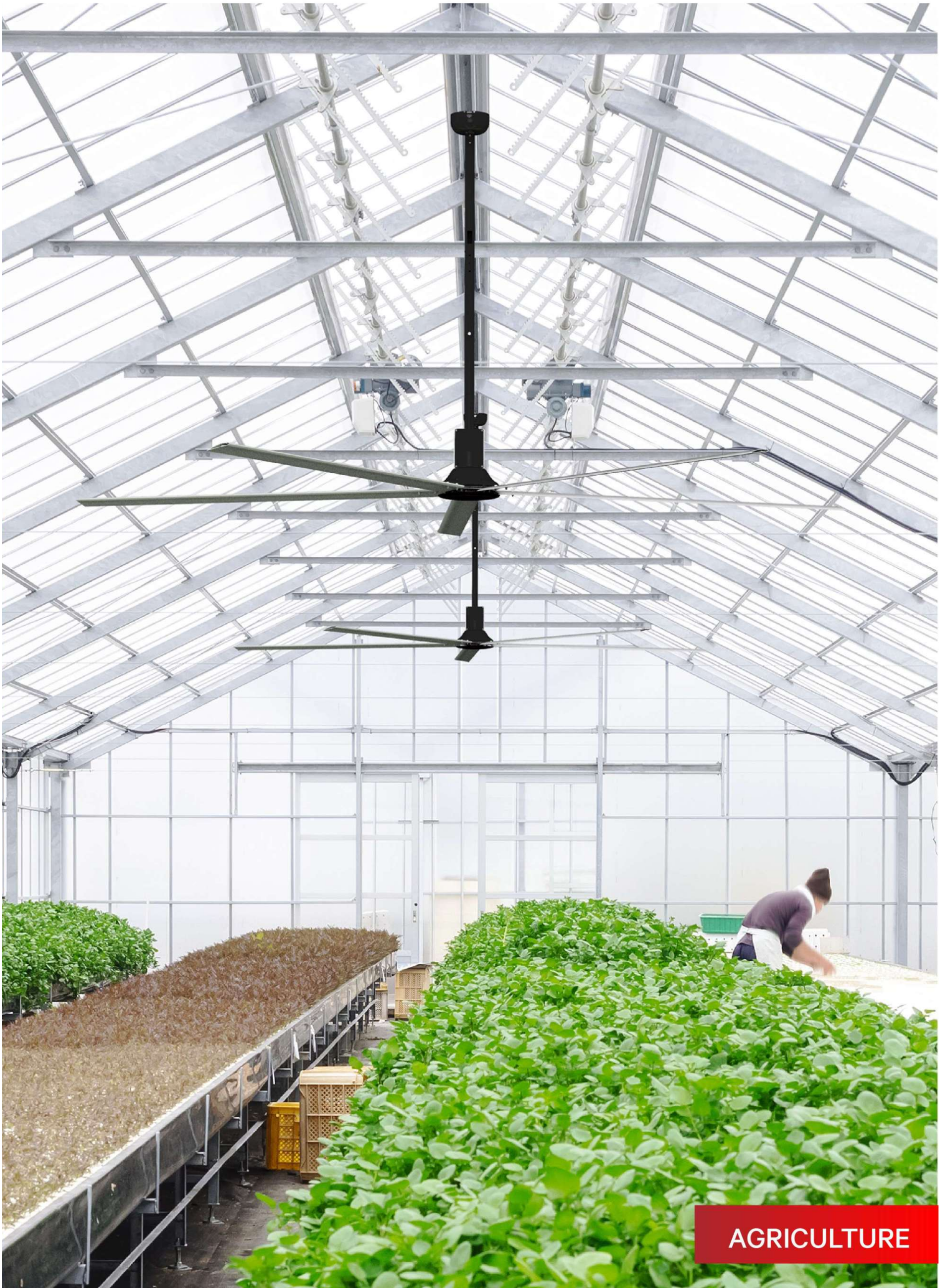

AGRICULTURE

SPORTS CENTRES

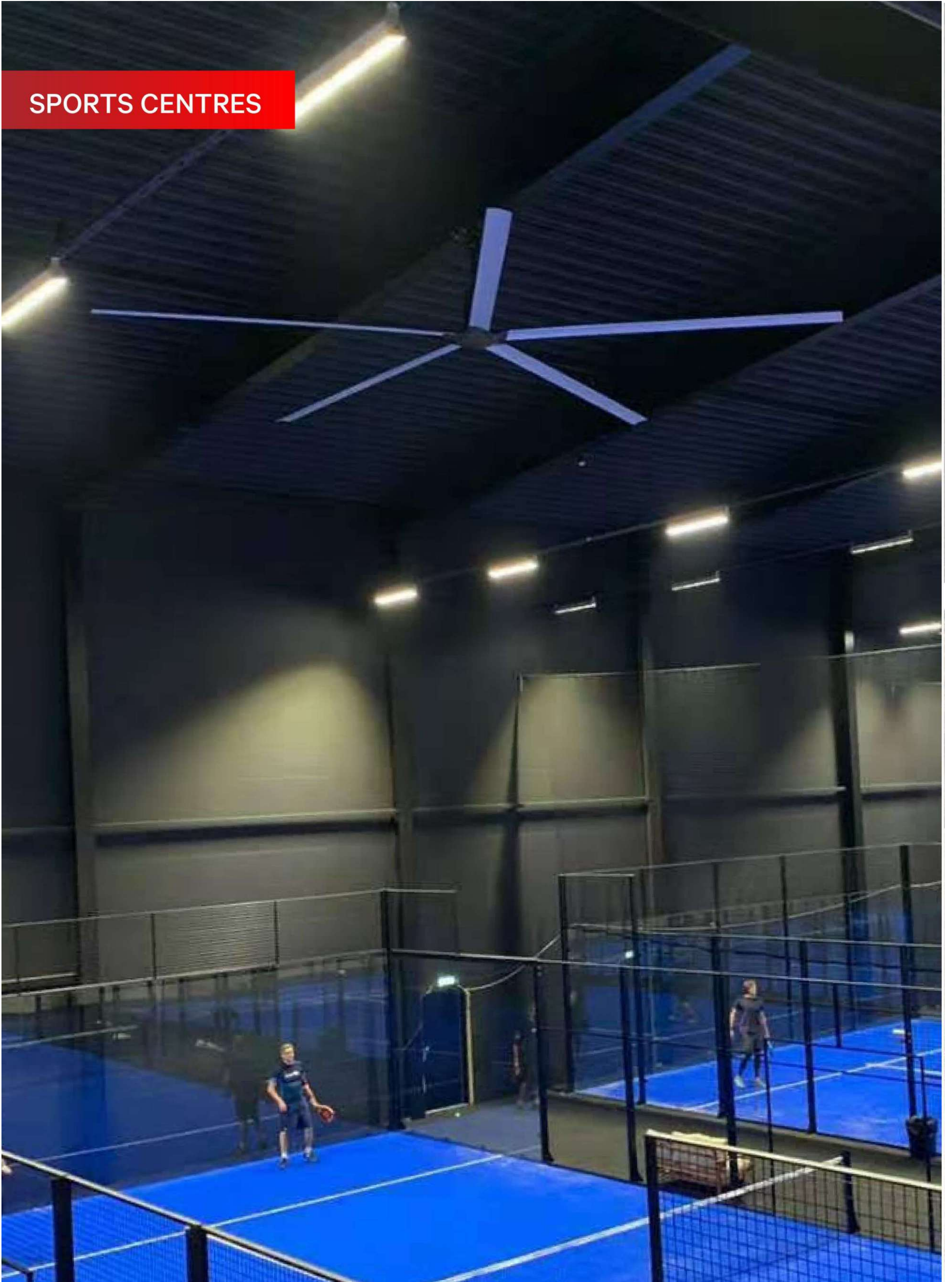

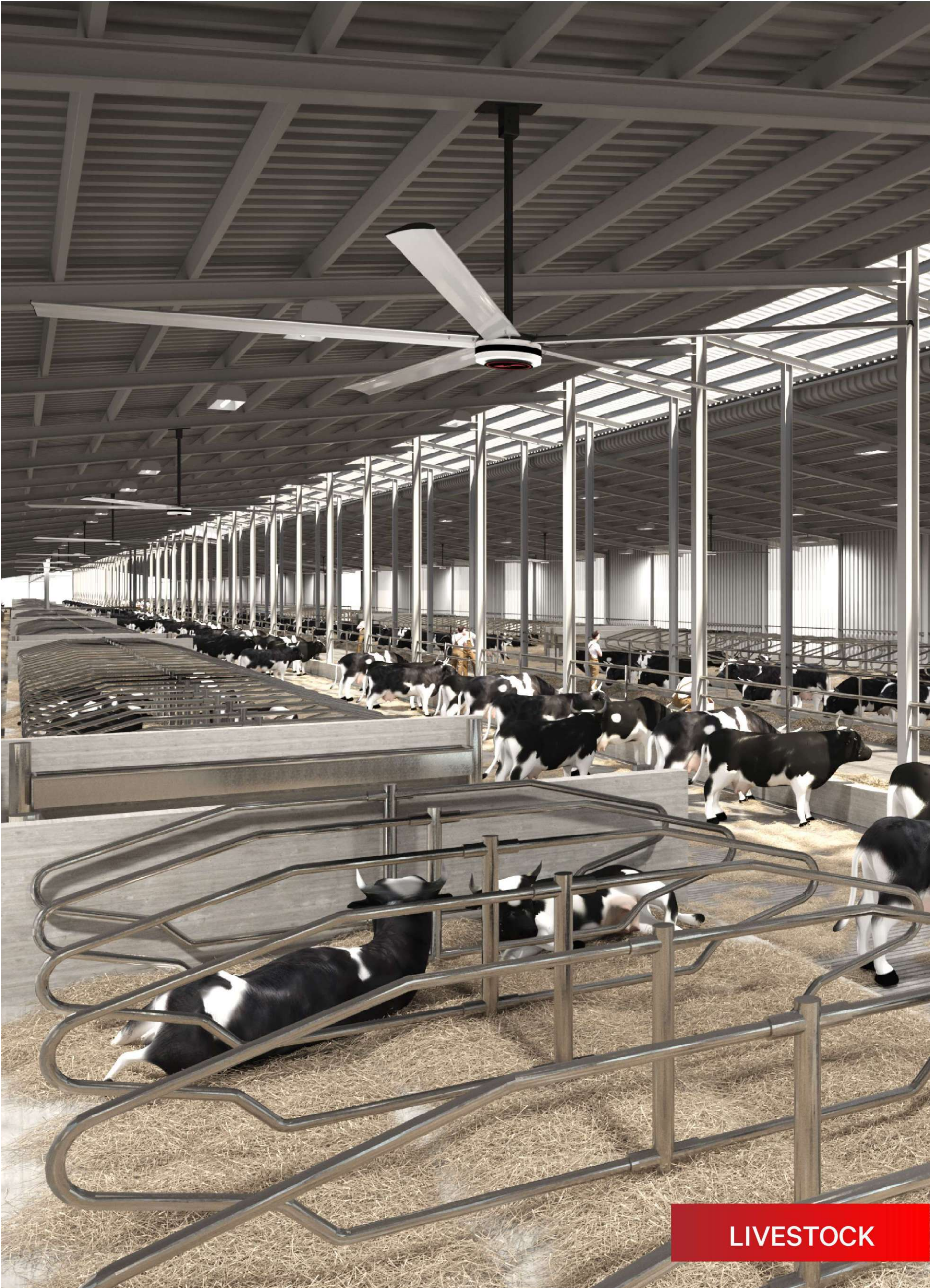

LIVESTOCK

M650



FEATURES

- ▶ 5 anodized aluminium blades
- ▶ Quick and easy installation
- ▶ Energy-efficient operation
- ▶ Network available for up to 20 fans
- ▶ 7 speed settings
- ▶ Available in custom-painted colors
- ▶ Wireless remote and IOT available
- ▶ Forward 0-100% speed
- ▶ Conforms to CE, EN, and IEC standards
- ▶ Multiple redundancies in all critical components, including blades, motors, electronics, and mount

Motor
Technology:
Direct drive
technology

Benefits:
No oil
No seals to leak
Only 2 moving parts
Low noise
Low energy consumption
Low weight

Radial Flux Machine
Motor Type

Benefits:
Cost effective
Scalable torque
Low energy losses

USES

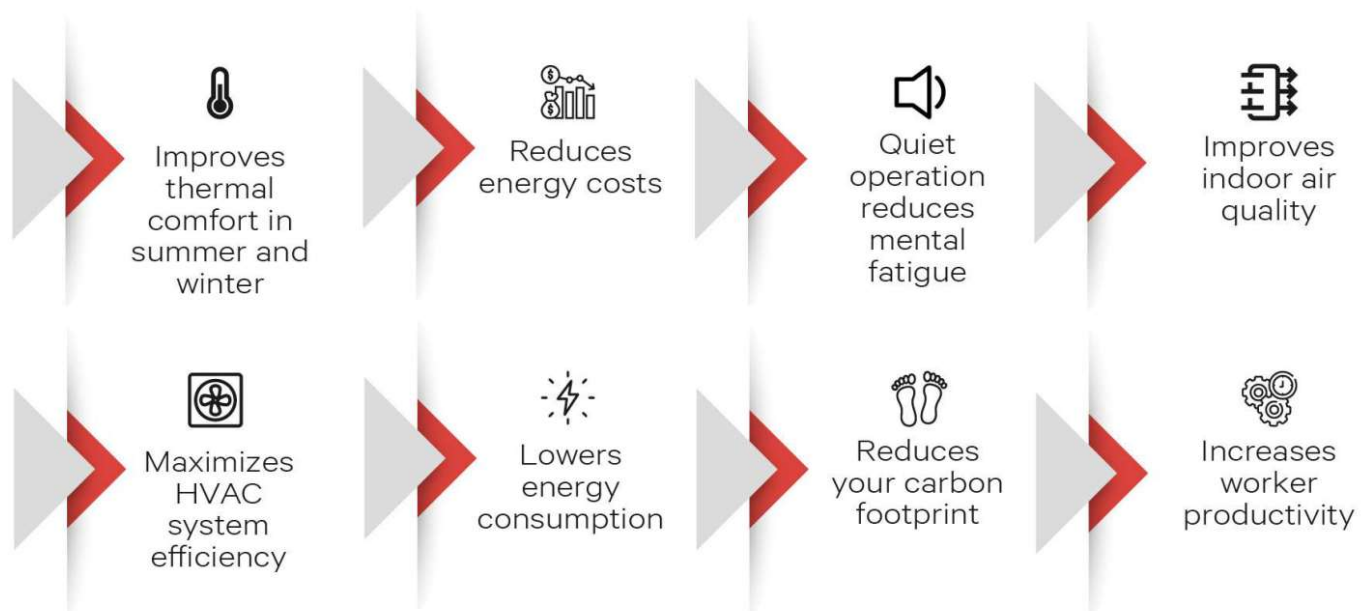

The M650 provides extreme value with its radial flux machine motor type. This gives it scalable torque and enables it to operate at top speed while consuming just 275 watts of power. The fan's easy installation process makes it an ideal fit for commercial spaces that are looking for a cost-effective way to cool the air. The M650 Series has been built to provide maximum value. This starts with its effortless installation process, which requires only a single cable. The M650's drive features a built-in HMI, which is located at floor level for a sleek look. This makes bringing the M650 into your facility an extremely low-cost endeavor. The M650 Series delivers comfortable airflow throughout the year. It cools efficiently in summer and equalizes a building's temperature in the winter to warm it. This model works best in medium-sized spaces with ceiling heights ranging from 9ft to 23ft. It's available in diameters spanning from 10ft to 14ft to suit your building's needs.

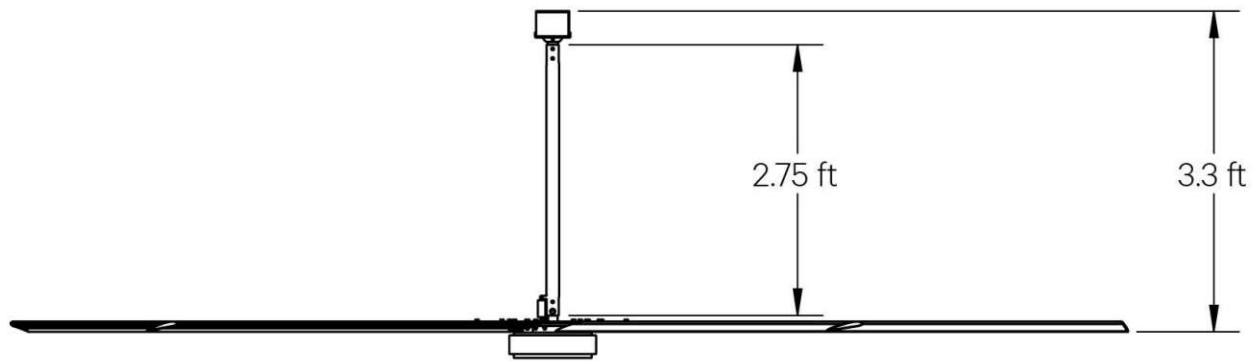

General Specifications

Voltage	208VAC - 240VAC Single Phase, 50Hz / 60Hz
Sound @ Max Speed	<45 dBA
IP Rating	IPX5 Indoor/Outdoor
Temperature Rating	14° F / +122° F
Certifications	CE, CB for local IEC Certification
Controller	Forward Direction 0-100%
Mounting	Fully Adjustable
Mount to Blades Height	3.3ft
Warranty	3 Years on all Parts - Extended Warranty Optional

Models/ Performance	Diameter	Number of Blades	Weight	Max Rotation Speed	Covered Area	Recommended Blade Height	Power Usage (Top speed)
M650-10	10 ft	5	69 lbs	112 rpm	2500 ft ²	15-23 ft	175 W
M650-12	12 ft	5	76 lbs	100 rpm	3800 ft ²	15-23 ft	250 W
M650-14	14 ft	5	83 lbs	78 rpm	5200 ft ²	15-23 ft	275 W

M750



FEATURES

- ▶ 5 anodized aluminium blades
- ▶ Quick and easy installation
- ▶ Energy-efficient operation
- ▶ Network for up to 20 fans
- ▶ 7 speed settings
- ▶ Forward 0-100% speed
- ▶ Safety cable, 5 blade retainer links for extreme safety
- ▶ Available in custom-painted colors
- ▶ Conforms to CE, EN, and IEC standards
- ▶ Wireless remote and IOT available
- ▶ Multiple redundancies in all critical components, including blades, motors, electronics, and mount

Motor Technology: Direct drive technology	Benefits: No oil No seals to leak Only 2 moving parts Low noise Low energy consumption Low weight	Radial Flux Machine Motor Type	Benefits: Cost effective Scalable torque Low energy losses
---	--	---------------------------------------	--

USES

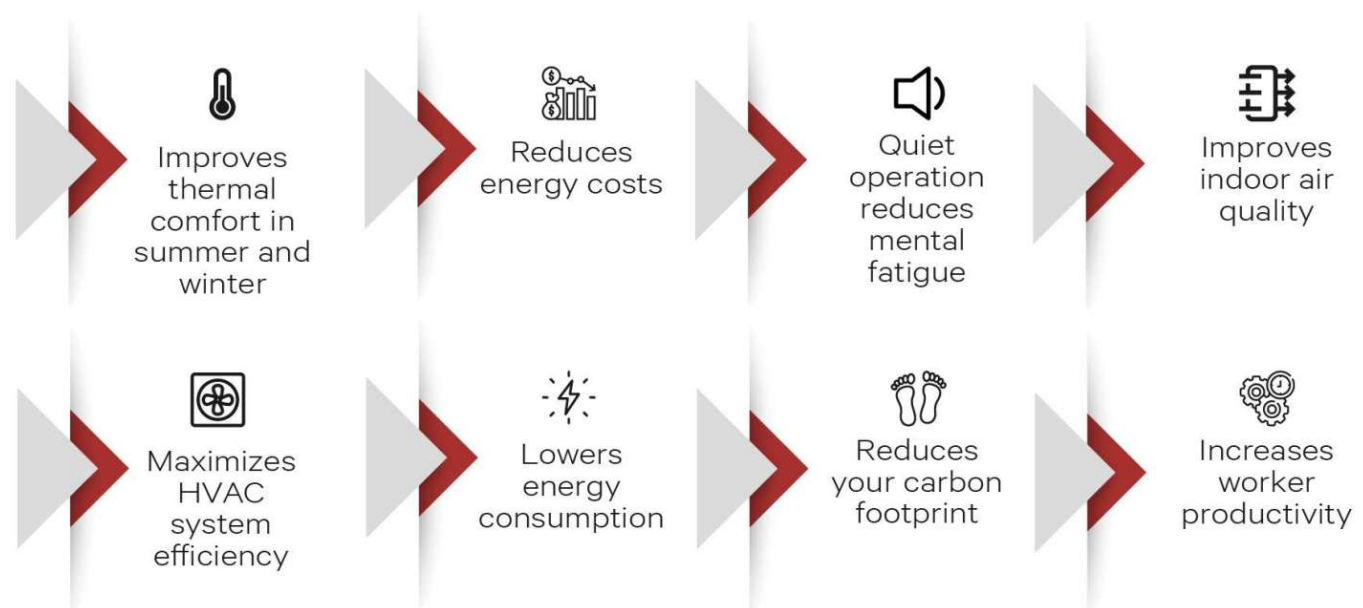

The M750 delivers high performance cooling with its powerful radial flux motor, but manages to consume just 700 watts of energy at its top speed. That unique combination provides extreme value in large industrial spaces and elsewhere. The fan's energy savings will allow you to earn a fast return on your investment. The M750 Series has been designed for maximum value. It features a built-in HMI that's located at floor level to reduce installation and maintenance costs. Its sleek design only requires a single cable from the ceiling to the floor in order to operate it. The M750 Series provides comfortable quiet airflow in the summer and equalizes temperatures in the winter. It works best in large spaces, with ceiling heights ranging from 23ft to 50ft. The M750 Series is available in diameters ranging from 16ft to 24ft to suit your building's needs.

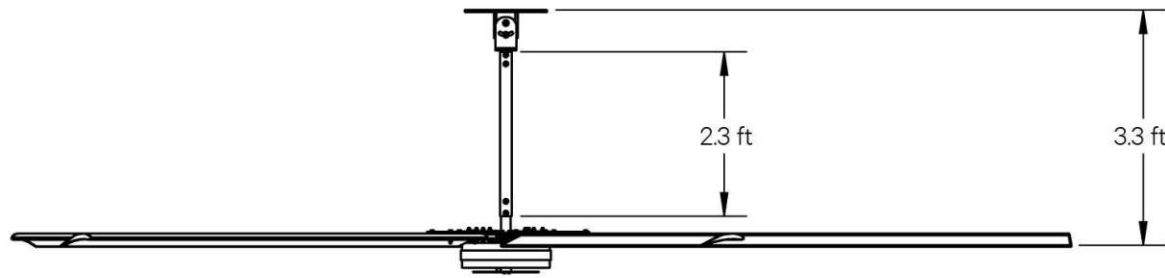

General Specifications

Voltage	208VAC - 240VAC Single Phase, 50Hz / 60Hz
Sound @ Max Speed	<50 dBA
IP Rating	IPX5 Indoor/Outdoor
Temperature Rating	14° F / +122° F
Certifications	CE, CB for local IEC Certification
Controller	Forward Direction 0-100%
Mounting	Fully Adjustable
Mount to Blades Height	3.3ft
Warranty	3 Years on all Parts - Extended Warranty Optional

Models/ Performance	Diameter	Number of Blades	Weight	Max Rotation Speed	Covered Area	Recommended Blade Height	Power Usage (Top speed)
M750-16	16 ft	5	221 lbs	78 rpm	6500 ft ²	20-33 ft	413 W
M750-18	18 ft	5	230 lbs	69 rpm	8100 ft ²	20-33 ft	490 W
M750-20	20 ft	5	239 lbs	53 rpm	10000 ft ²	20-33 ft	460 W
M750-24	24 ft	5	255 lbs	48 rpm	14000 ft ²	20-33 ft	700 W

CONTROLLER

HMI BI 1-20



Technical Data

Display	LCD
Input voltage	208-240 VAC
Output current	7Amp max.
Speed	7 levels
Dimensions	9.2" x 5.9" x 3.6"
Weight	5 lbs
Operating temperature	14° F – 122° F
Degree of protection	IP20

FEATURES

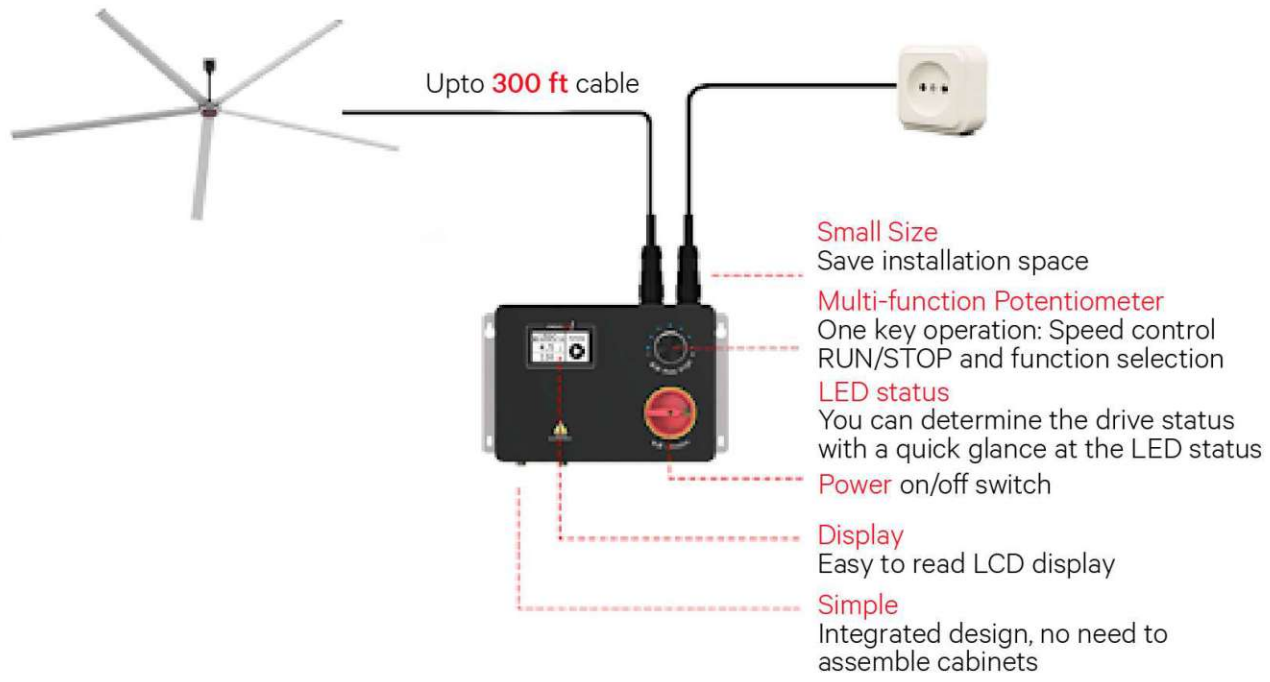

Wireless remote control:

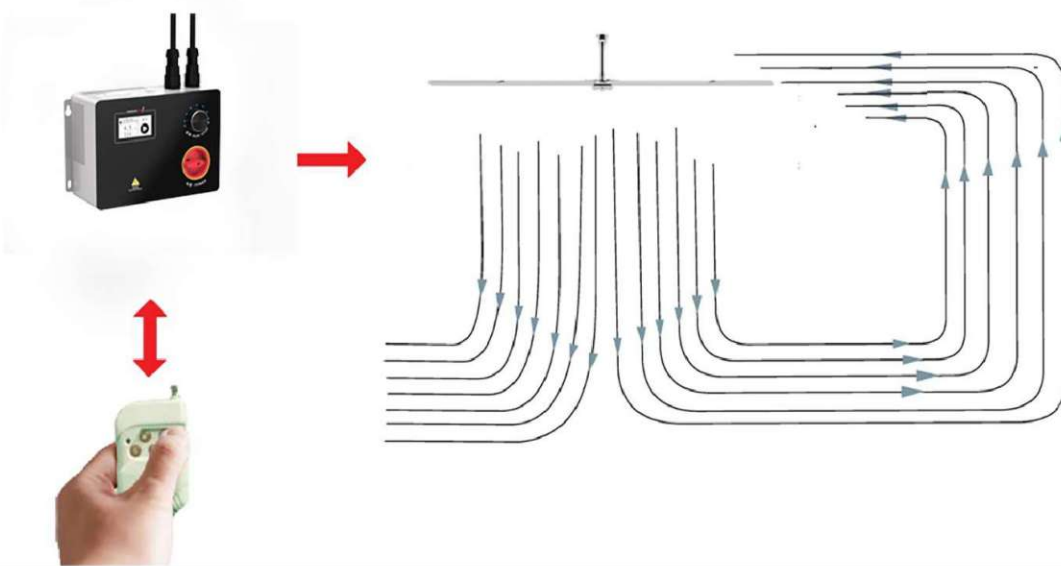

Smart internet of things:

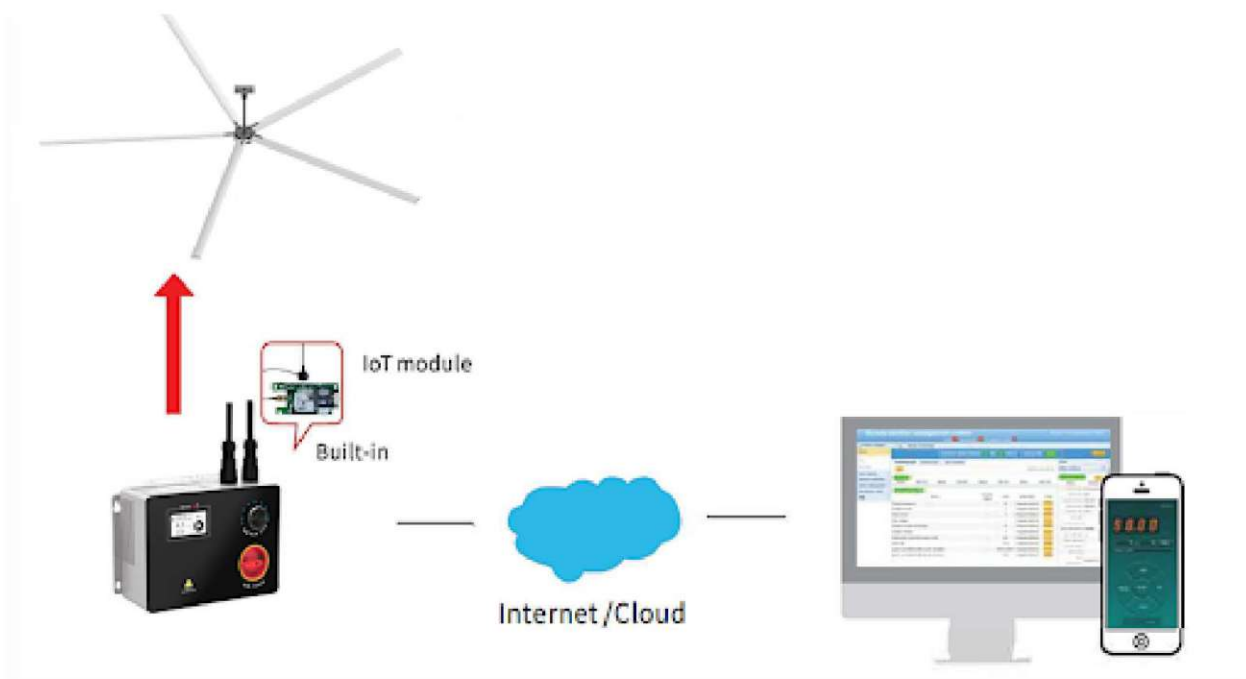

TECHNOLOGY DIRECT DRIVE

Gearbox Driven Technology

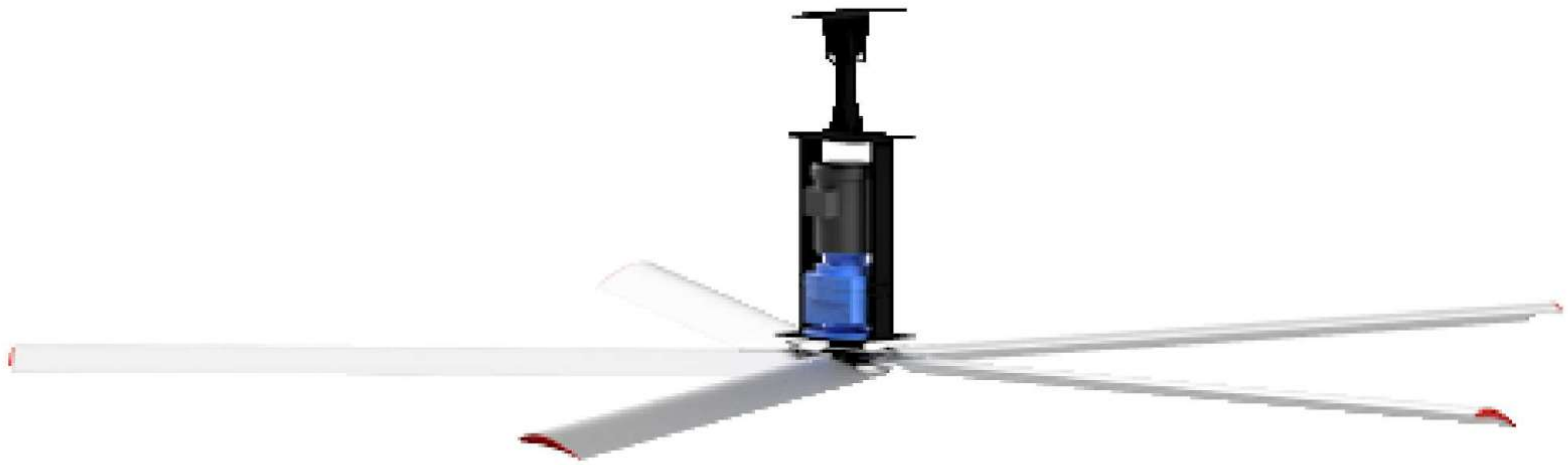

FAILURE POINTS AND DRAWBACKS

- ▶ Gearbox with oil
- ▶ Seal failure after few years
- ▶ Loud operation
- ▶ Heavy
- ▶ High energy losses

Direct Drive Technology



BENEFITS

- ▶ No Oil
- ▶ No Seals to leak
- ▶ Only 2 moving parts
- ▶ Low Noise
- ▶ Low energy consumption
- ▶ Low weight

PLEASANTLY QUIET

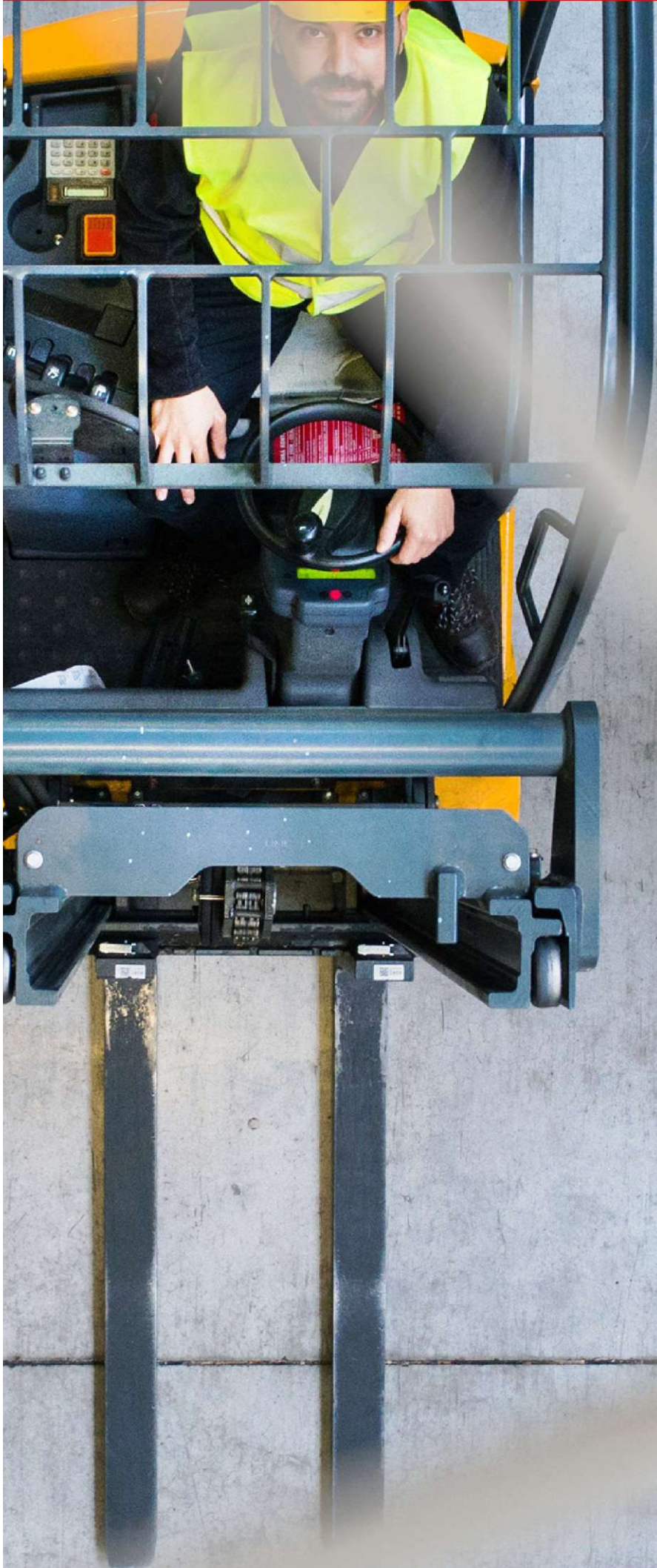

ENERGY-EFFICIENT



COMPANY OVERVIEW

It takes time to reach the impressive levels of design and performance that Vindus Fans' HVLS fans offer today. It all started 30 years ago in Huskvarna, Sweden when our engineering team found themselves surrounded by boat designers, water park designers and motor tuning specialists. These early encounters inspired the team to work towards their own lofty engineering goals.

Since then, the team has worked tirelessly to bring its vision to life. They've turned that passion into Vindus Fans and have used their experience to create the most efficient designs and produce the most robust offerings of products in the industry. The team's dedication has been well worth it. In January 2019, Vindus Fans opened its first operation branch in Spain; in 2020 the time for the far east arrived with an opening in Qingdao, China; and in 2021, The United States followed. Vindus is now positioned perfectly to serve customers around the world.



**PERFORMANCE IS OUR PASSION &
RELIABILITY IS OUR MOTIVATION**



OUR PURPOSE

We exist to make industrial and commercial spaces more comfortable by offering energy saving solutions.

OUR VISION

To provide HVLS fans and support that exceed the expectations of our customers. This vision inspires everything that we do, giving us our sense of direction and a destination to work towards. It captures our aspiration of being the best at what we do, becoming the global leader in HVLS technology.

OUR MISSION

To build long term relationships with our customers and clients, and to provide exceptional customer service. We're achieving this by expanding our business with a focus on innovation and advanced technology, providing the most reliable, energy-efficient HVLS fans in the market.

CONTACT

📍 USA

Vindus Fans Corp.
12724 Gran Bay Parkway West
Bartram Park, Suite 410
Jacksonville, FL 32258, USA
inquiry@vindusfans.com

📍 SPAIN

Vindus Fans
Pol. Ind. Ingruinsa,
Av da del Puerto 12-13
46520 Puerto de Sagunto, Spain
inquiry@vindusfans.com

📍 SWEDEN

Vindus Building Efficiency
Sjögårdsvägen 24
56192 Huskvarna, Sweden
inquiry@vindusfans.com

📍 CHINA

Vindus (Qingdao) Environmental
Technology Co. Ltd., Room 3227,
Sino-German EcoPark Double Innovation Center,
No. 172 Taibaishan Road,
Qingdao Area Of China (Shandong), China
Pilot Free Trade Zone

LOCATIONS



vindusfans.com